

DISCRETE OPTIMIZATION OF A GEAR PUMP AFTER TOOTH UNDERCUTTING BY MEANS OF COMPLEX MULTI-VALUED LOGIC TREES

Adam DEPTUŁA, Marian A. PARTYKA

Abstract: A discrete optimization of a gear pump based on logic decision trees is aimed at defining the importance of construction and exploitation parameters that is guidelines concerning the sequence of decisions taken from the point of view of the realization of the system aim and stability function. The choice of exploitation parameters for a given pump construction decides about its maximum efficiency. It is possible to adopt a mono-criterion or a multi-criteria approach in order to optimize the pump efficiency. Original solution in this work is to treat the parameters: Q with n and p with M as a single decision variables-on the floors of the common complex decision trees.

Keywords: optimization, multiple-valued logic function, gear pump after tooth undercutting, complex multiple-valued logic trees.

1. Introduction

Hydraulic machines are one of the most widespread machine classes, without which it would be hard to imagine the functioning of modern industry and of society today. These machines can be divided into pumps, water turbines, hydrokinetic drives, mixers, water-jet drives, propellers etc., but also hydraulic transport, hydraulic drive and hydraulic steering, etc. [6, 9]. Overflow machines form a wide group of systems. The work of overflow machines is most frequently based on two states: transient state (in which values of the system functions change in time) and steady state (the functions values do not change in time or change periodically). Changes of construction parameters x_1, x_2, \dots, x_n have an influence on the behavior of functions f_1, f_2, \dots, f_n depending on time t [2]. A model of design process of a given hydraulic system must make it possible to agree to appropriate relations and regularities necessary to describe the process as far as quantity is concerned.. A model of design process of a given hydraulic system must make it possible to agree to appropriate relations and regularities necessary to describe the process as far as quantity is concerned. It should also take into consideration possibilities of development of a given system in the structural and parametric scope [6].

Owing to their capacity to transmit high powers at a relatively high efficiency hydraulic systems have been increasingly used. Fluid flow energy generators are one of the principal components of any hydraulic system. Various optimization algorithms, e.g. the systematic search method, the Monte Carlo method and the gradient method, are employed [10]. The method of discrete optimization by means of multivalent logic trees, presented in this paper represents a new approach to the problem. The application of the method is illustrated for a novel gear pump with tooth root relief [12].

2. Gear pump after tooth root undercutting

The tested prototype unit was designed in-house and manufactured by the Hydraulic Pumps Manufacturing Company Ltd. in Wrocław. The pump was designed having in mind the technological capacities of this company. The novelty of the prototype pump consists in the modification of the involute profile in its upper part through the so-called tooth root relief (undercut). The innovation and analysis of a gear pump after tooth root undercutting were made by Osiński from Wrocław University of Technology [9, 12].

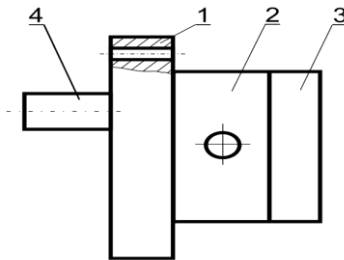

Fig.1. Three-plate design of gear micropump with external meshing.
1 – front (mounting) plate, 2 – middle (rest) plate, 3 – rear plate
4 – driving shaft

The designed and built prototype pump has a three-plate structure shown schematically in fig. 1. The front plate (1) is used for mounting the pump on the drive unit. The middle plate (2) contains gear wheels, slide bearing housings and suction and forcing holes for connecting to a hydraulic system. The whole construction is closed with a rear plate (3).

2.1. Measuring stand

The static characteristics of the pump with tooth root relief and its circumferential damping were determined using the stand shown in fig. 2.

Tests were carried out after the trial starting of the stand, i.e. after the operation of the pump and the safety valve and the indications of all the measuring instruments had been checked. Measuring began with setting the prescribed shaft rotational speeds $n = 500, 800, 1000, 1500$ and 2000 rpm. Pump loading was effected for $p_t = 0, 5, 10, 15, 20, 25, 28$ and 30 MPa. The maximum forcing pressure was limited by the measuring range of torque meter 21. The static characteristics were tested at a constant working fluid temperature of 50°C .

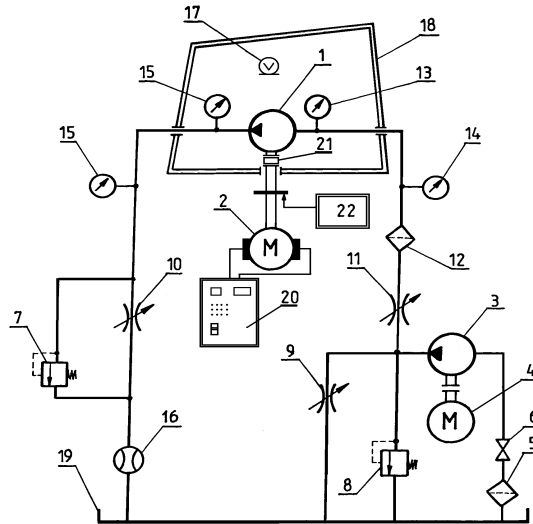

Fig. 2. Schematic of test stand: 1-tested pump, 2-driving DC motor, 3-feed pump, 4-AC motor, 5-suction filter, 6-cut-off valve, 7,8-safety valves, 9,10,11-cut-off valve, 12-drain filter, 13,14-manovacuometer 15-pressure gauge, 16-flowmeter with microammeter, 17-measuring microphones, 18-sound chamber, 19-tank, 20-electronic rpm adjustment system, 21-torque sensor with recorder, 22-photocell with measuring counter

3. Hydraulic properties of a gear pump

Choosing appropriate efficiency for a gear pump will make it possible to save energy. Total efficiency of a pump is determined by the ratio of power output N_{wy} to power input N_{we} or a product of volumetric efficiency and the hydraulic and mechanical efficiency [10]:

$$\eta_c = \frac{N_{wy}}{N_{we}} \cong \eta_v \eta_{hm} \quad (1)$$

The pump volumetric efficiency η_v is the ratio of a real displacement Q_{rz} to theoretical displacement Q_t :

$$\eta_v = \frac{Q_{rz}}{Q_t} \quad (2)$$

The total volumetric loss in the pump are composed of: partial filling of chambers during suction, compressibility of liquids, pump elements deformation, internal leaks, proportional to viscosity and density of liquids. Analysing all coefficients and appropriate dependencies among them, the following formula is obtained [9]:

$$\eta_v = 1 - c_\mu \frac{p}{2\pi\mu \cdot n} - c_r \frac{1}{n} \sqrt{\frac{2p}{\rho}} \sqrt[3]{q^{-1}} \quad (3)$$

where:

c_μ - coefficient, which is a function of dimensions and the number of gaps also depends on the efficiency of an appropriate pump,

p - working pressure,

q - proper efficiency,

n - rotational speed,

μ - liquid dynamic viscosity,

c_r - coefficient depending on the type of gaps, their dimensions and efficiency of an appropriate pump,

Hydraulic and mechanical pump efficiency η_{hm} is a ratio of a theoretical moment M_t to the sum of hydraulic and mechanical loss moment ΔM and the theoretical moment M_t :

$$\eta_{hm} = \frac{M_t}{M_t + \Delta M} \quad (4)$$

and thus, in the end, it has the following formula:

$$\eta_{hm} = \frac{1}{1 + c_v 2\pi \frac{\mu \cdot n}{p} + c_\rho 2\pi \frac{\rho \cdot n^2}{2p} \sqrt[3]{q^2} + c_p} \quad (5)$$

where:

c_p - coefficient depends mostly on the pump type,

c_ρ - coefficient depends mostly on the proper efficiency,

c_v - coefficient depends on the pump type.

Finally, the useful efficiency can be presented in the following form:

$$\eta_c = \frac{1 - c_\mu \frac{p}{2\pi\mu \cdot n} - c_r \frac{1}{n} \sqrt{\frac{2p}{\rho}} \sqrt[3]{q^{-1}}}{1 + c_v 2\pi \frac{\mu \cdot n}{p} + c_\rho \frac{\rho \cdot n^2}{2p} \sqrt[3]{q^2} + c_p} \quad (6)$$

The results of measurements of static characteristics of an experimental pump after tooth root undercutting are presented in the Table 1 [12].

Tab. 1. Hydraulic measurement results [12]

n [rpm]	p_t [Mpa]	Q_{rz} [l/min]	M [Nm]	N_h [kW]	N_m [kW]	η_v [%]	η_{hm} [%]	η_c [%]
500	≈ 0	21,1	2,0	0,00	0,10	94,6	0,0	0,0
	5	20,5	36,0	1,70	1,88	92,1	98,0	90,3
	10	20,3	77,0	3,38	4,03	91,3	91,8	83,8
	15	20,2	116,0	5,05	6,07	90,9	91,5	83,1
	20	20,2	156,0	6,73	8,17	90,9	90,7	82,4
	25	20,5	200,0	8,53	10,47	92,1	88,5	81,5
	28	20,6	218,0	9,60	11,41	92,5	90,9	84,1
	30	20,7	236,0	10,34	12,36	93,0	90,0	83,6
800	≈ 0	34,9	2,0	0,00	0,17	98,0	0,0	0,0
	5	34,7	38,0	2,88	3,18	97,5	92,8	90,5
	10	34,3	78,0	5,70	6,53	96,2	90,6	87,2
	15	34,2	118,0	8,53	9,89	96,0	89,9	86,3
	20	34,1	160,0	11,34	13,40	95,7	88,4	84,6
	25	34,5	202,0	14,38	16,92	97,0	87,6	85,0
	28	34,7	224,0	16,19	18,77	97,5	88,5	86,3
	30	34,8	240,0	17,39	20,11	97,8	88,5	86,5
1000	≈ 0	44,5	2,2	0,00	0,23	99,9	0,0	0,0
	5	44,1	38,0	3,66	3,98	99,1	92,8	92,0
	10	43,9	82,0	7,30	8,59	98,7	86,2	85,1
	15	43,4	124,0	10,83	12,99	97,4	85,6	83,4
	20	43,4	168,0	14,44	17,59	97,4	84,2	82,1
	25	43,4	208,0	18,05	21,78	97,4	85,1	82,9
	28	43,4	234,0	20,22	24,50	97,4	84,7	82,5
	30	43,3	249,0	21,62	26,08	97,2	85,3	82,9
1500	≈ 0	67,3	6,0	0,00	0,94	100,9	0,0	0,0
	5	66,8	42,0	5,54	6,60	100,0	84,0	84,0
	10	66,5	84,0	11,06	13,19	99,6	84,1	83,8
	15	66,1	125,0	16,51	19,63	99,1	84,9	84,1
	20	65,5	172,0	21,80	27,02	98,1	82,3	80,7
	25	65,7	210,0	27,34	32,99	98,4	84,2	82,9
	28	65,6	235,0	30,58	36,91	98,2	84,3	82,8
	30	65,5	255,0	32,72	40,06	98,1	83,3	81,7
2000	≈ 0	89,3	8,0	0,00	1,68	100,3	0,0	0,0
	5	89,0	47,0	7,39	9,84	100,0	75,0	75,0
	10	88,3	94,0	14,69	19,69	99,3	75,2	74,6
	15	88,0	138,0	21,96	28,90	98,8	76,9	76,0
	20	87,6	182,0	29,17	38,12	98,4	77,8	76,5
	25	88,0	214,0	36,62	44,82	98,8	82,7	81,7
	28	87,9	241,0	40,98	50,47	98,7	82,2	81,2
	30	87,8	259,0	43,86	54,24	98,6	82,0	80,9

In this study, functions: η_v , η_{hm} , η_c are the criterion functions of purpose whereas parameters n , p_t , Q_{rz} are decision variables. Such an approach makes sense from the point of view of using a given gear pump in different systems and determining calculation divergence because of various algorithms of the gear pump design [9] e.g. determining the maximum volumetric efficiency with permissible hydraulic and mechanical efficiency and determining the maximum total efficiency.

The Figures 3 present exemplary charts of total volumetric and hydraulic and mechanical efficiency for the speed $n = 500$. Exemplary characteristic of the moment and power is shown in Figures 4[12].

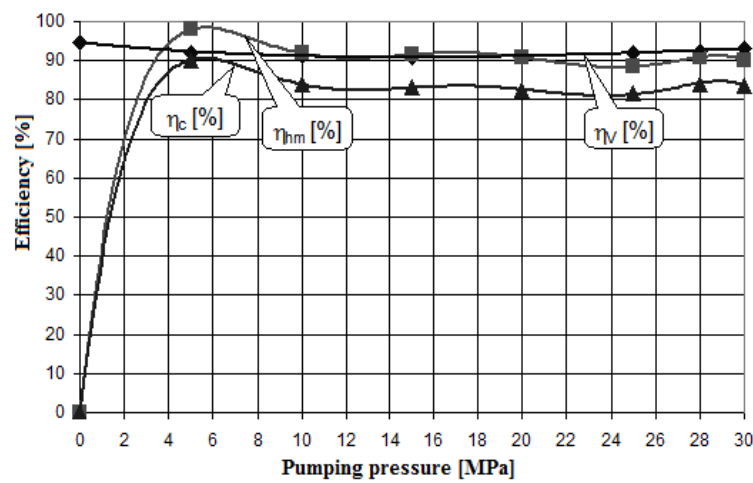

Fig. 3. Characteristics of experimental pump efficiency for $n = 500$ rpm.

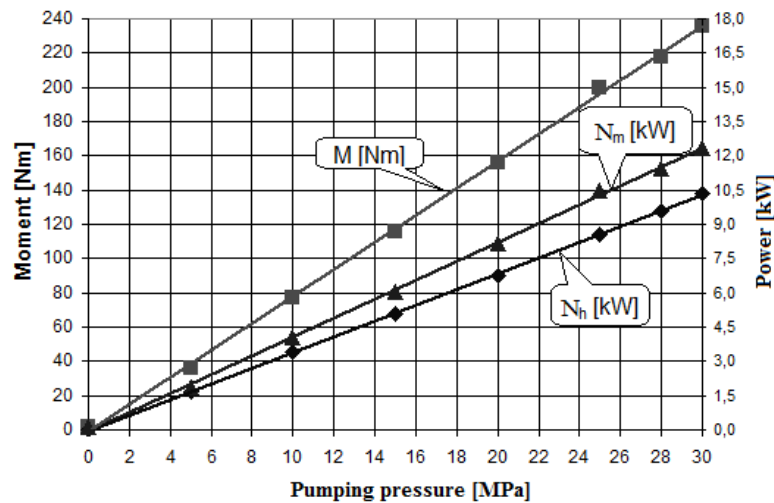

Fig. 4. Characteristics of the moment and experimental pump power for $n = 500$ rpm.

4. Discrete optimization of a gear pump after tooth root undercutting

A gear pump optimization requires calculating volumetric, hydraulic and mechanical, as well as total efficiency. The pump efficiency optimization can be multi-criteria or mono-criterion. Assuming that the total pump efficiency is the function of purpose and the parameters we are looking for are values of construction and/or exploitation parameters, then optimization can be made separately for construction and exploitation parameters looking for the maximum efficiency value [6, 7, 10, 12].

4.1. Multiple-valued logic decision trees

Complex multiple-valued logic functions determine the degree of importance of logic variables by changing the levels of the logic tree, from the most important (near the root) to the least important (on the top) because there is a generalisation of a Boolean quality index into a multiple-valued one; $(C_k - k_i m_i) + (k_i + K_i)$, where C_k – the number of branches of k -level, k_i – multiplicity of simplification on k -level, m_i – value of i - variable, K_i – the number of branches $(k-1)$ – level, out of which branches of k -level were formed which cannot be simplified. In this way it is possible to obtain the minimum complex alternative normal form. All transformations are described by the so-called Quine–McCluskey algorithm based on the minimization of individual partial multiple-valued logic functions [1, 2, 4].

Example 1.

For a multiple-valued logic function $f(x_1, x_2, x_3)$, where $x_1, x_2, x_3 = 0, 1, 2$, written by means of numbers KAPN: 100, 010, 002, 020, 101, 110, 021, 102, 210, 111, 201, 120, 022, 112, 211, 121, 212, 221, 122, there is one MZAPN after the application of the Quine–McCluskey algorithm based on the minimization of individual partial multiple-valued logic functions having 13 literals [11]:

$$f(x_1, x_2, x_3) = j_0(x_1)(j_0(x_2)j_2(x_3) + j_1(x_2)j_0(x_3) + j_2(x_2)) + j_1(x_1) + j_2(x_1)(j_0(x_2)j_1(x_3) + j_1(x_2) + j_2(x_2)j_1(x_3))).$$

Figure 5 shows MAPN of a given multi-valued logic function.

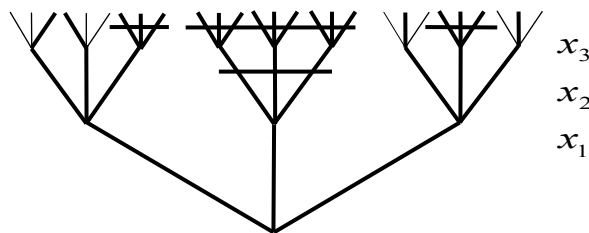

Fig. 5. MAPN of a given multiple-valued logic function

4.2. Complex logic trees in the analysis of a degree of importance of the gear pump after tooth root undercutting construction parameters

Complex logic trees are a kind of logic trees in which at least two or more decision variables occur together at one floor of tree.

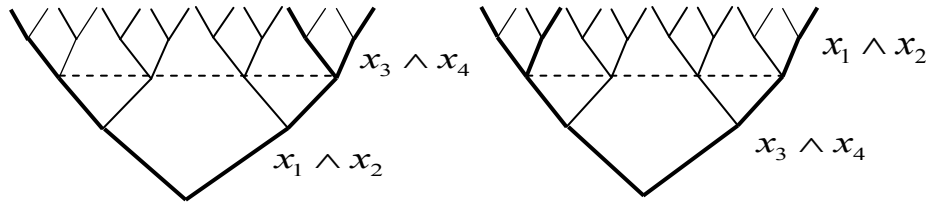

Fig. 6. Complex decision trees for $x_1 \wedge x_2$ and $x_3 \wedge x_4$

Complex decision trees presented in the Fig. 6 include two levels described by an implication of variables $x_1 \wedge x_2$ and $x_3 \wedge x_4$. A complex multiple-valued logic tree specifies the same degree of importance for at least two joined decision parameters. During an optimization process of machine systems, the criteria set very frequently includes various competitive and apparent inconsistencies. Complex decision trees allow to join construction and/or exploitation parameters of similar properties as well as of the same adopted discretization of interval values. It makes it possible to decrease the calculation complexity in order to specify the most important subgroups of the whole set or system. In case of joining decision variables of separate properties and functions that they have in the system, a subanalysis of a given set or system is obtained.

In the analysed example, an analysis of a degree of importance of a gear pump construction parameters was made for joined parameters $p \wedge M$ and $Q \wedge n$. Arithmetic values of analysed parameters have been chosen in order to make an analysis in accordance with a table. These values had been coded by means of logic decision variables for the needs of logic decision trees:

- $n = 500$ [rpm] ~ 0 ; $n = 800$ [rpm] ~ 1 ; $n = 1000$ [rpm] ~ 2 ;
- $n = 1500$ [rpm] ~ 3 ; $n = 2000$ [rpm] ~ 4 ;
- $p_t \approx 0$ [MPa] ~ 0 ; $p_t = 5$ [MPa] ~ 1 ; $p_t = 10$ [MPa] ~ 2 ; $p_t = 15$ [MPa] ~ 3 ;
- $p_t = 20$ [MPa] ~ 4 ; $p_t = 25$ [MPa] ~ 5 ; $p_t = 28$ [MPa] ~ 6 ; $p_t = 30$ [MPa] ~ 7 ;
- $Q_{rz} \in \langle 20, 2; 21, 1 \rangle$ [l/min] ~ 0 ; $Q_{rz} \in \langle 34, 2; 34, 9 \rangle$ [l/min] ~ 1 ;
- $Q_{rz} \in \langle 43, 3; 44, 5 \rangle$ [l/min] ~ 2 ; [l/min] ~ 3 ; $Q_{rz} \in \langle 87, 6; 89, 3 \rangle$ [l/min] ~ 4 ;
- $M \in \langle 2, 0; 8, 0 \rangle$ [Nm] ~ 0 ; $M \in \langle 36, 0; 47, 0 \rangle$ [Nm] ~ 1 ; $M \in \langle 77, 0; 94, 0 \rangle$ [Nm] ~ 2 ;
- $M \in \langle 116, 0; 138, 0 \rangle$ [Nm] ~ 3 ; $M \in \langle 156, 0; 182, 0 \rangle$ [Nm] ~ 4 ; $M \in \langle 200, 0; 214, 0 \rangle$ [Nm] ~ 5 ;
- $M \in \langle 210, 0; 241, 0 \rangle$ [Nm] ~ 6 ; $M \in \langle 236, 0; 259, 0 \rangle$ [Nm] ~ 7 .

While looking for an optimal function value η_v , η_{hm} , η_c , the following arithmetic scopes of changes have been adopted: $\eta_v \geq 0,96$; $\eta_{hm} \geq 0,89$; $\eta_c \geq 0,86$.

Tab. 2. Arithmetic and logic values of the agreed parameters and the function of purpose

n [rpm]	Q _{rz} [l/min]	p _t [Mpa]	M [Nm]	η _v [%]	η _{hm} [%]	η _c [%]
0	0	0	0	94,6	0,0	0,0
		1	1	92,1	98,0	90,3
		2	2	91,3	91,8	83,8
		3	3	90,9	91,5	83,1
		4	4	90,9	90,7	82,4
		5	5	92,1	88,5	81,5
		6	6	92,5	90,9	84,1
		7	7	93,0	90,0	83,6
1	1	0	0	98,0	0,0	0,0
		1	1	97,5	92,8	90,5
		2	2	96,2	90,6	87,2
		3	3	96,0	89,9	86,3
		4	4	95,7	88,4	84,6
		5	5	97,0	87,6	85,0
		6	6	97,5	88,5	86,3
		7	7	97,8	88,5	86,5
2	2	0	0	99,9	0,0	0,0
		1	1	99,1	92,8	92,0
		2	2	98,7	86,2	85,1
		3	3	97,4	85,6	83,4
		4	4	97,4	84,2	82,1
		5	5	97,4	85,1	82,9
		6	6	97,4	84,7	82,5
		7	7	97,2	85,3	82,9
3	3	0	0	100,9	0,0	0,0
		1	1	100,0	84,0	84,0
		2	2	99,6	84,1	83,8
		3	3	99,1	84,9	84,1
		4	4	98,1	82,3	80,7
		5	5	98,4	84,2	82,9
		6	6	98,2	84,3	82,8
		7	7	98,1	83,3	81,7
4	4	0	0	100,3	0,0	0,0
		1	1	100,0	75,0	75,0
		2	2	99,3	75,2	74,6
		3	3	98,8	76,9	76,0
		4	4	98,4	77,8	76,5
		5	5	98,8	82,7	81,7
		6	6	98,7	82,2	81,2

		7	7	98,6	82,0	80,9
--	--	---	---	------	------	------

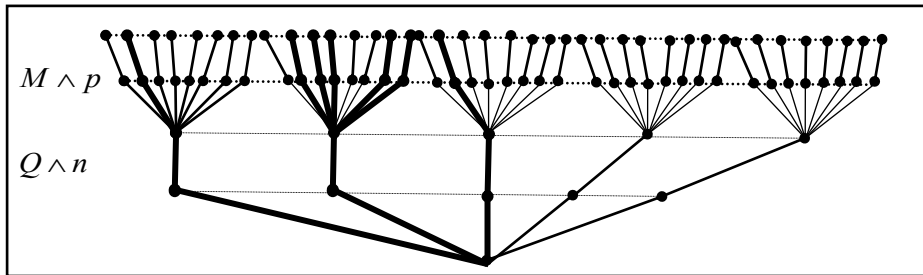
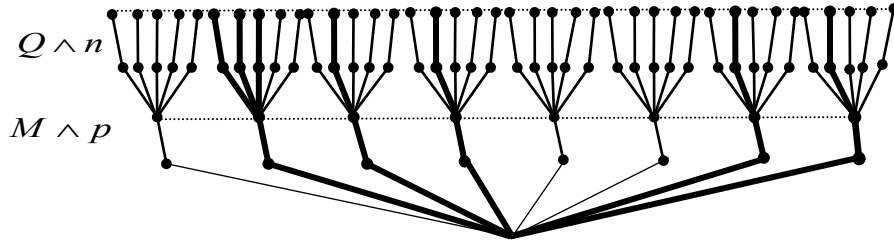

Fig.7. Multiple-valued logic trees for the η_c efficiency; □- Optimal multiple-valued logic tree

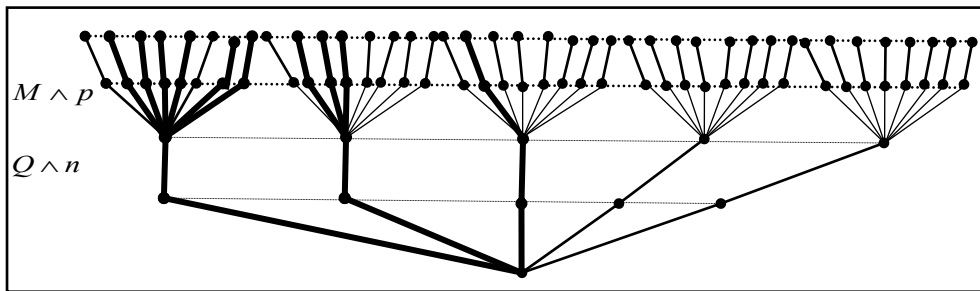
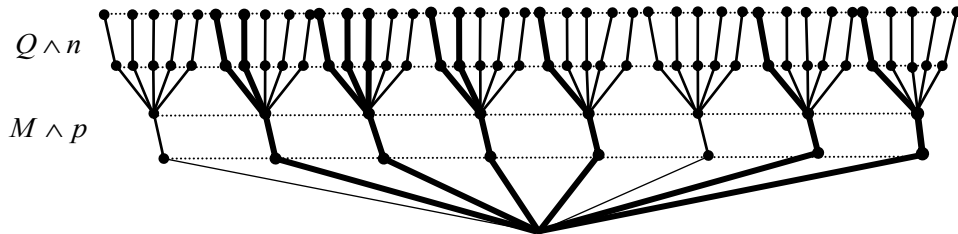

Fig. 8. Multiple-valued logic trees for the η_{hm} efficiency; □- Optimal multiple-valued logic tree

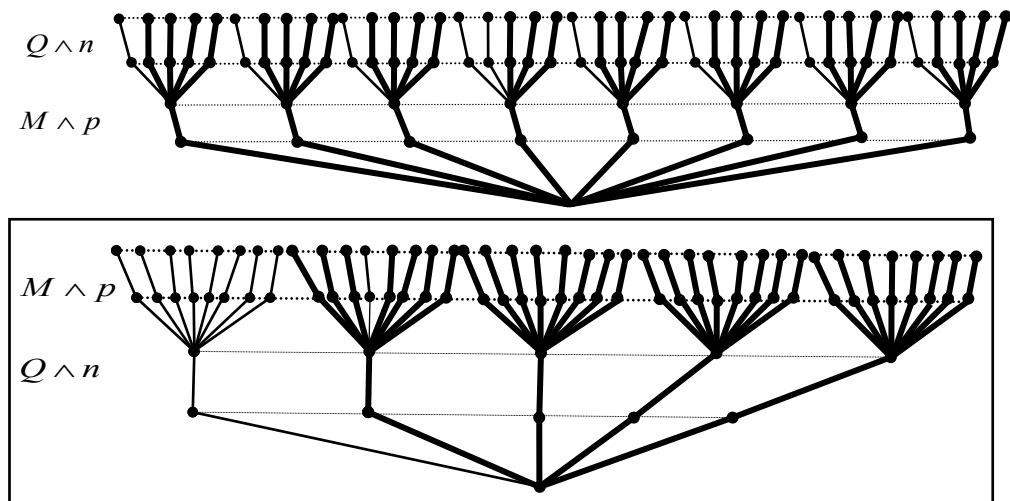

Fig. 9. Multiple-valued logic trees for the η_v efficiency; □- Optimal multiple-valued logic tree

If we treat p and M as separate decision variables and adopt a decreased multi-value for M , that is: $M \in \langle 2, 0; 47, 0 \rangle$ [Nm] ~ 0 ; $M \in \langle 77, 0; 125, 0 \rangle$ [Nm] ~ 1 ; $M \in \langle 138, 0; 182, 0 \rangle$ [Nm] ~ 2 ; $M \in \langle 200, 0; 259, 0 \rangle$ [Nm] ~ 3 , : then, for efficiency η_v optimum decision tree is shown in Figures 10.

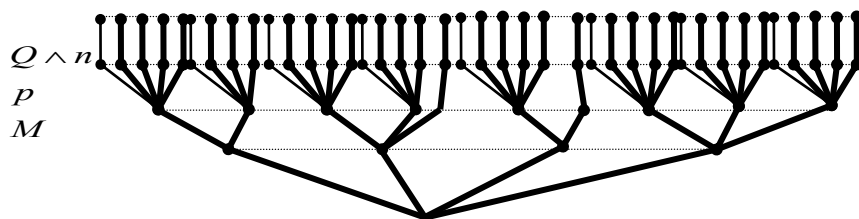

Fig. 10. Optimal multiple-valued logic tree for the η_v efficiency-for separate parameters M and p

5. Conclusion

For the Table 2 complex decision trees were received successively for the following efficiency: η_c (Figure 7), η_{hm} (Figure 8) and η_v (Figure 9). Designing of an element or a system can be made in accordance with an optional order of changes for parameters but only logic trees with a minimum number of real branches, describe the real degree of importance of construction and/or exploitation parameters from the most important one at the bottom to the least important one at the top. For complex decision trees shown in the

pictures 7-9, optimum logic trees always have a complex decision variable $Q \wedge n$ in the tree root. In a general case, individual properties of individual construction and/or exploitation parameters decide on their degree of importance.

References:

1. Deptuła A.: Determination of game-tree structures complexity level in discrete optimization of machine systems, International Masaryk Conference for Ph. D. students and young researches. December 12-16, 2011. Hradec Kralove, Czech Republic.
2. Deptuła A.: Coefficient of the structure complexity for multi-valued decision logic trees XLI Konf. Zast. Mat., Zakopane 2012, Inst. Mat. PAN, Warszawa 2012.
3. Deptuła A., Partyka M.A.: Application of game graphs in optimization of dynamic system structures. International Journal of Applied Mechanics and Engineering, 2010, vol.15, No.3, pp. 647-656.
4. Deptuła A., Partyka M. A.: Separate logical analysis of design guidelines with taking into consideration uncertainty in the machine systems modelling. Journal of Transdisciplinary Systems Science, 2012, vol.16, No.1, pp. 161-173, ISSN 1427-275X.
5. Deptuła A., Partyka M. A.: Separate logical analysis of design guidelines in the machine systems modelling, International Journal of Applied Mechanics and Engineering, 2012, vol.17, No.3, pp. 779-790, ISSN 1425-1655.
6. Francis J., Betts P. L.: Modelling Incompressible Flow in a Pressure Relief Valve. Proceedings of the Institution of Mechanical Engineers, Part E: Journal of Process Mechanical Engineering, Vol. 211, No. 2/1997, 83-93
7. Huang J.K., Chang R.W., Lian Ch. W.: An Optimization Approach to the Displacement Volumes for External Spur Gear Pumps, Materials Science Forum Vol. 594 (2008).
8. Jain T.K., Kushwaha D.S., Misra A.K.: Optimization of the Quine-McCluskey Method for the Minimization of the Boolean Expressions. International Conference on Autonomic and Autonomous Systems, (ICAS), 2008.
9. Kollek W., Osiński P.: Modelling and design of gear pumps. Wydawnictwo PWR, Wrocław 2009.
10. Kollek W.: Gear pumps, their construction and exploitation. Wyd. Ossolineum, Wrocław 1996.
11. McCluskey E.J.: Minimization of Boolean functions, Bell System Tech. Journal, vol.35, No.5, pp. 1417-1444, 1956.
12. Osiński P.: Impact of the tooth root undercutting on hydraulic and acoustic properties of gear pump; Raport PRE nr 14/2005; Politechnika Wroclawska. Wrocław 2005.
13. Partyka M. A., The Quine- Mc Cluskey minimization algorithm of individual multiple- valued partial functions for digital control systems, 3rd Inter. Confer. Syst. Engin., Wright State University, Dayton 1984.

MSc Eng. Adam DEPTUŁA
Prof. Marian A. PARTYKA
Opole University of Technology
Department of Knowledge Engineering

75 Ozimska Street, 45-370 Opole, Poland
phone/fax: (0-77) 44 98 845
e-mail: a.deptula@po.opole.pl